

# 10,000 L On-Farm Diesel - with Skid

## Safe fill level 10,000L

**TOLERANCES**  
 UNLESS NOTED OTHERWISE  
 PLEASE ALLOW BELOW TOLERANCES  
 DIMENSIONS <200mm - ALLOW ± 3mm  
 DIMENSIONS 200 - 1000mm - ALLOW ± 5mm  
 DIMENSIONS >1000mm - ALLOW ± 10mm

**PUMP OPTIONS AVAILABLE:**

- 80LPM 12V 4M Piusi Pump Package
- 56LPM 240V 6M Piusi Pump Package
- 90LPM 240V 8M Piusi Pump Package

**PUMP CABINET INCLUDES:**

- Auto Shut-off Trigger Nozzle & diesel hose
- 3 digit Mechanical Flow Meter
- Water Absorbing Filter (20 Micron)

50mm Camlock Inspection port

Max Safe Fill Level  
95% of Total Capacity

Sight level tube

Hot Dip Galvanised Steel  
Pump Stand

Powder Coated Lockable  
Steel Pump Cabinet

Diesel Fuel & Capacity  
Labelling

Sight level isolator valve

**FILL PIPE ASSEMBLY:**

- 50mm Hot Dip Gal Piping
- Camlock coupling
- Non-return Valve
- Ball Valve
- Internal Poly Anti splash fill pipe

Anti-Static Earth lead

20mm Poly Manhole plate.  
Rebated, screwed and sealed.

50mm Screened T-Vent

**HEAVY DUTY TANK:**

- Certified Diesel Grade Polyethylene
- Thicker walls than water tanks

50mm Drain Bung at the rear.

Hot Dip Galvanised  
Floor sheeting

Tie-down straps

Forklift Tubes  
(150 x 100 SHS)

Hot Dip Galvanised Skid

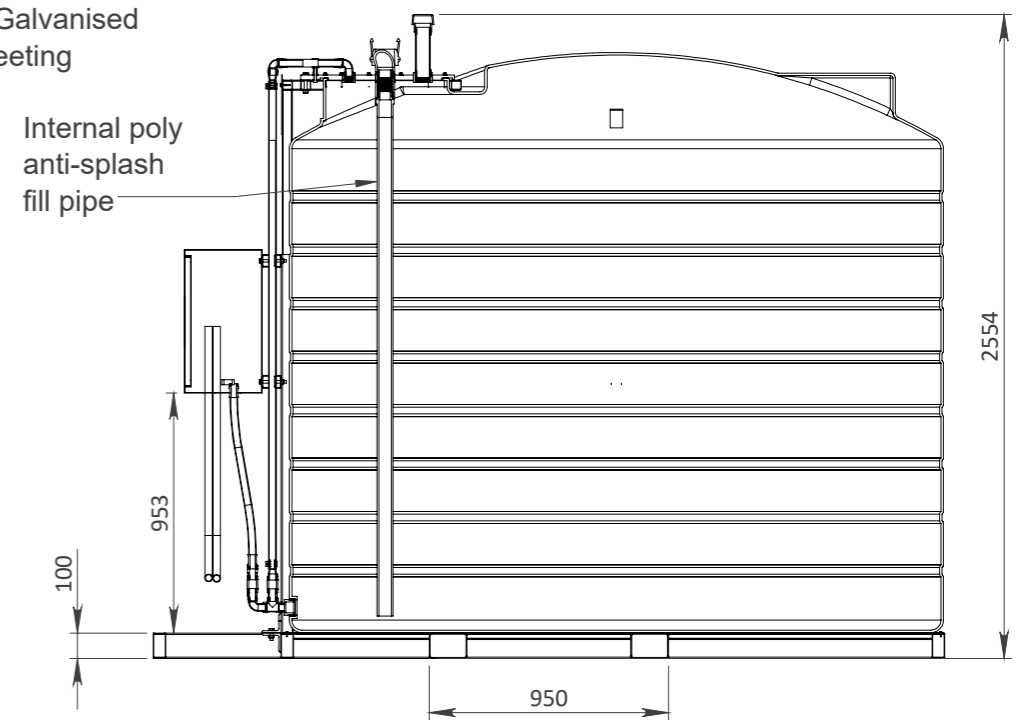
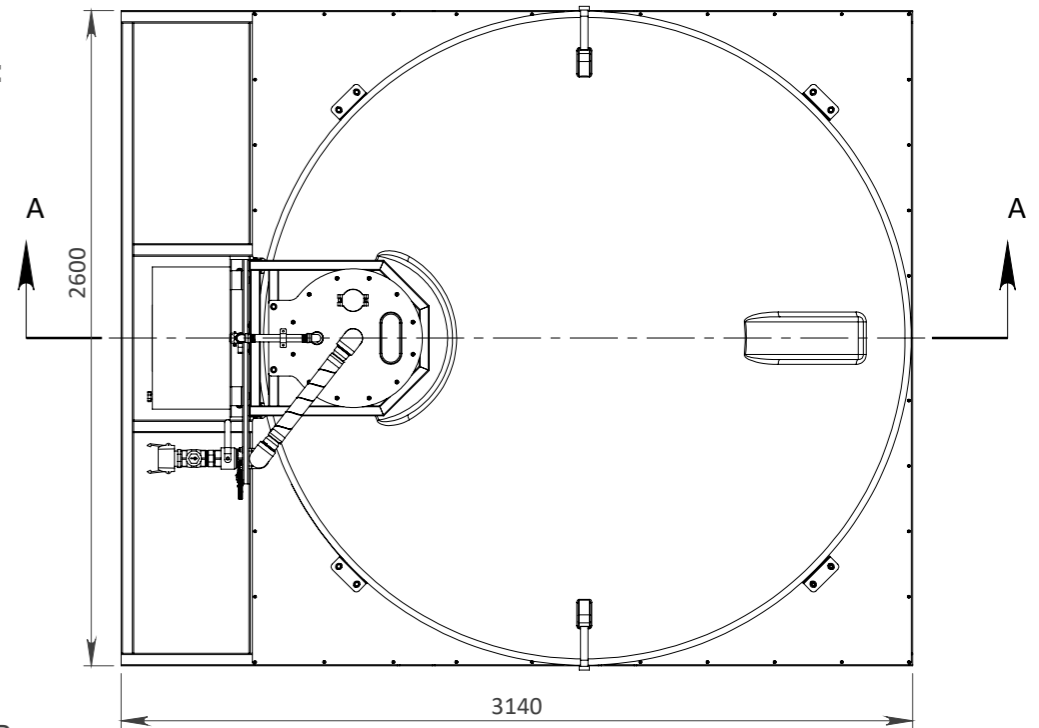

SECTION A-A

**AUST. STANDARDS COMPLIANCE:**

- AS1940:2017 (Storage of Combustible Liquids)
- AS1692:2006 (relevant sections)

0	21.03.24	PRELIMINARY ONLY	HP	DH	
REV	DATE	REVISION DESCRIPTION	DRAWN	CHKD.	ENG.



A.C.N. 010 028 547  
 Gough Industries Pty. Ltd.  
 833 Ingham Road  
 Bohle, Townsville  
 P.O. Box 7570, Garbutt BC, Qld. 4814.  
 Telephone 07 47747606  
 www.gough.com.au

Dimensions are in millimetres (mm) unless noted.

CLIENT LOGO.

10,000 L On-Farm Diesel - with Skid

SCALE  
NTS A3

GOUGH PLASTICS DRAWING No.

RUR-OFD-10000.1

REVISION  
0

SOLDWORKS: S:\Solidworks\Rural\Onfarm Diesel\10,000 L\10,000 L On Farm Diesel Assembly

PDF. FILE PATH: S:\Products\Rural\Marketing Rural\On Farm Diesel