

## 100L DIESEL SLIMLINE Underbody

**TOLERANCES**  
 NOTE: UNLESS NOTED OTHERWISE,  
 PLEASE ALLOW DIMENSIONAL TOLERANCES  
 DUE TO FABRICATION PROCESS AND  
 POLYETHYLENE THERMAL EXPANSION  
 DIMENSIONS <200mm - ALLOW ±3mm  
 DIMENSIONS 200 - 1000mm - ALLOW ± 5mm  
 DIMENSIONS >1000mm - ALLOW ± 10mm

MARK	PART	MATERIAL	QTY	PART CODE	DRAWING REF.
1	100L DIESEL SLIMLINE TANK	DIESEL GRADE POLYETHYLENE	1	BOX405.8100.3	
2	80/100L MOUNTING BKT.	1.6mm GALVANISED SHEETMETAL	2	PARBKT0047	PARBKT0047
3	BRACKET BOLT	M10 x 25 HEX HD. ZP.	8	PARSCR0305	
4	SPRING WASHER	M10 x3.5x2.2 ZP.	8	PARSCR0504	
5	FLAT WASHER	M10 25 O.D x 2mm ZP.	8	PARSCR0503	
6	1" BRASS INSERT	BRASS	1	PARSCR4025	
7	2" BLACK GROMMET	P769	2	PARPLF1780	
8	1/2" POLY PLUG	POLY PLUG , HEX W/O-RING	2	PARPLF1721	
9	10mm THREADED INSERTS	BRASS	8	PARSCR0003	

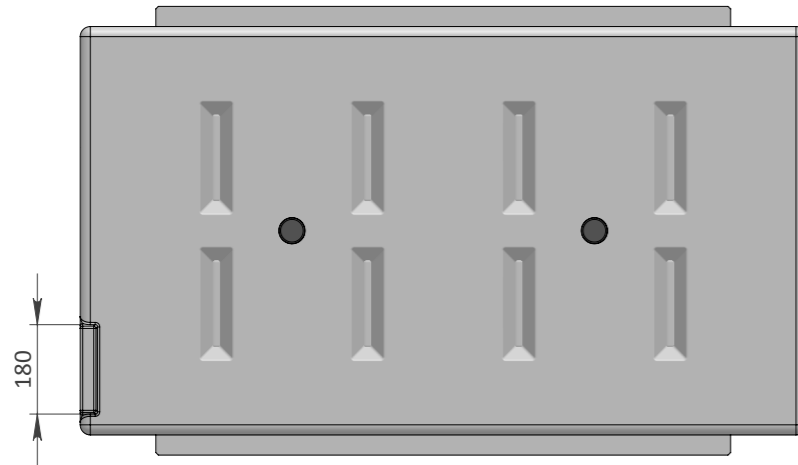

TOP VIEW

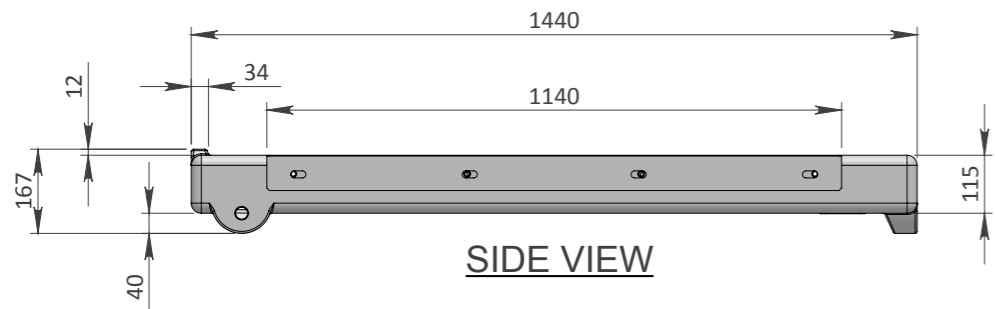

SIDE VIEW

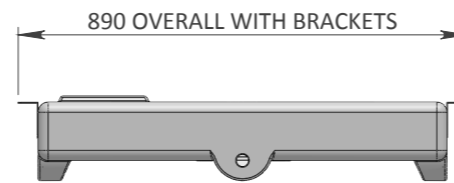

END VIEW

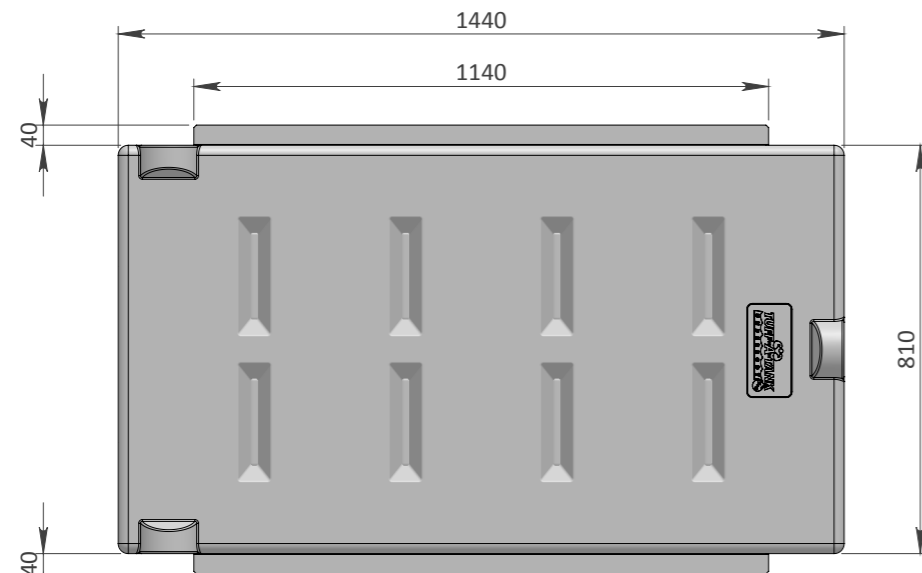

BOTTOM VIEW

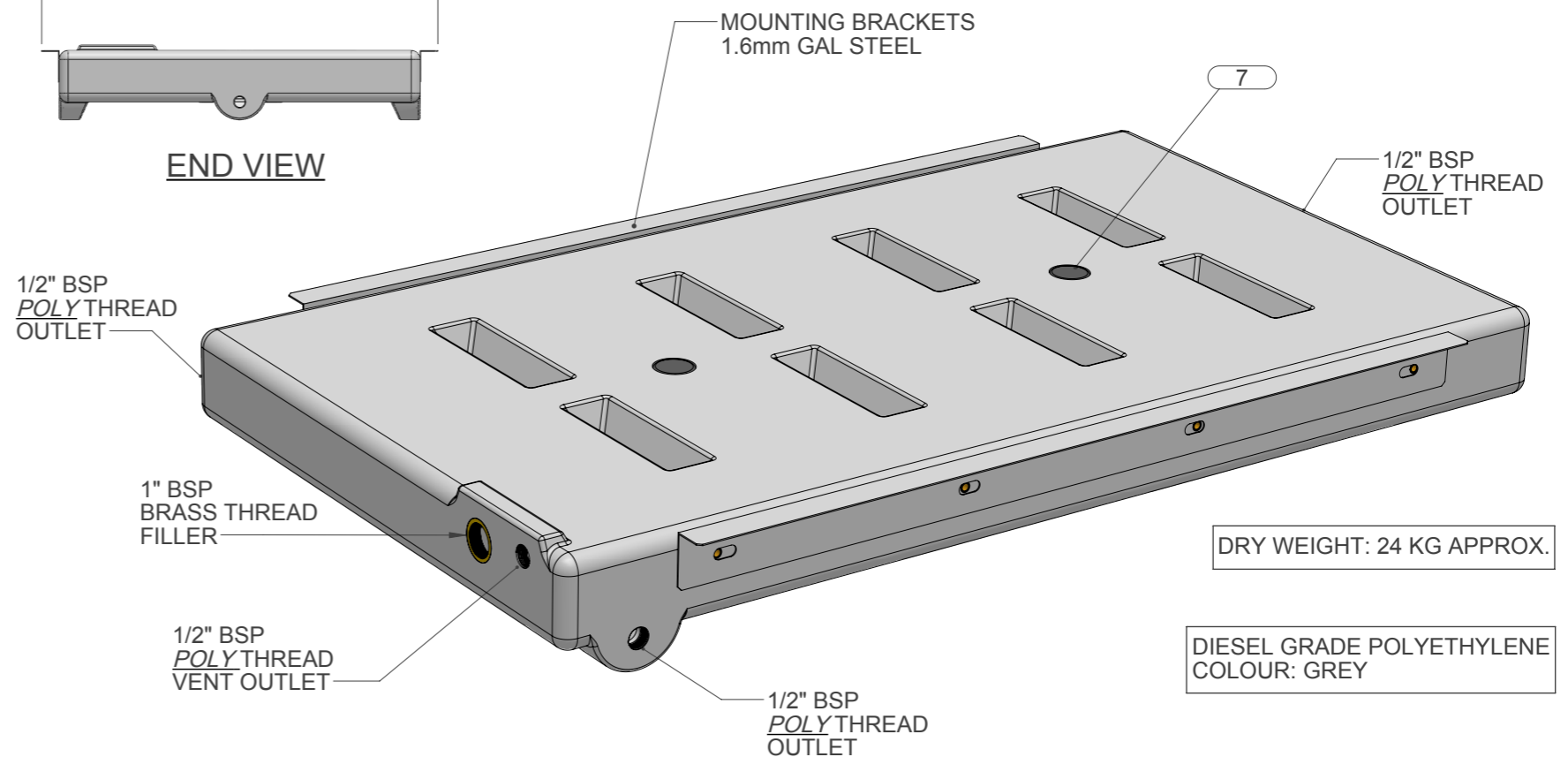

DRY WEIGHT: 24 KG APPROX.

DIESEL GRADE POLYETHYLENE  
COLOUR: GREY

REV	DATE	REVISION DESCRIPTION	DRAWN	CHKD	LEAD ENG
A	16.10.18	AS BUILT	DH		