

VS 65L CANOPY TANK DIAPHRAGM WATER (INC. DIAPHRAGM PUMP FITTED TO TOP OF TANK)

TOLERANCES
UNLESS NOTED OTHERWISE
PLEASE ALLOW BELOW TOLERANCES
DIMENSIONS <200mm - ALLOW ± 5 mm
DIMENSIONS 200 - 1000mm - ALLOW ± 10 mm
DIMENSIONS >1000mm - ALLOW ± 15 mm

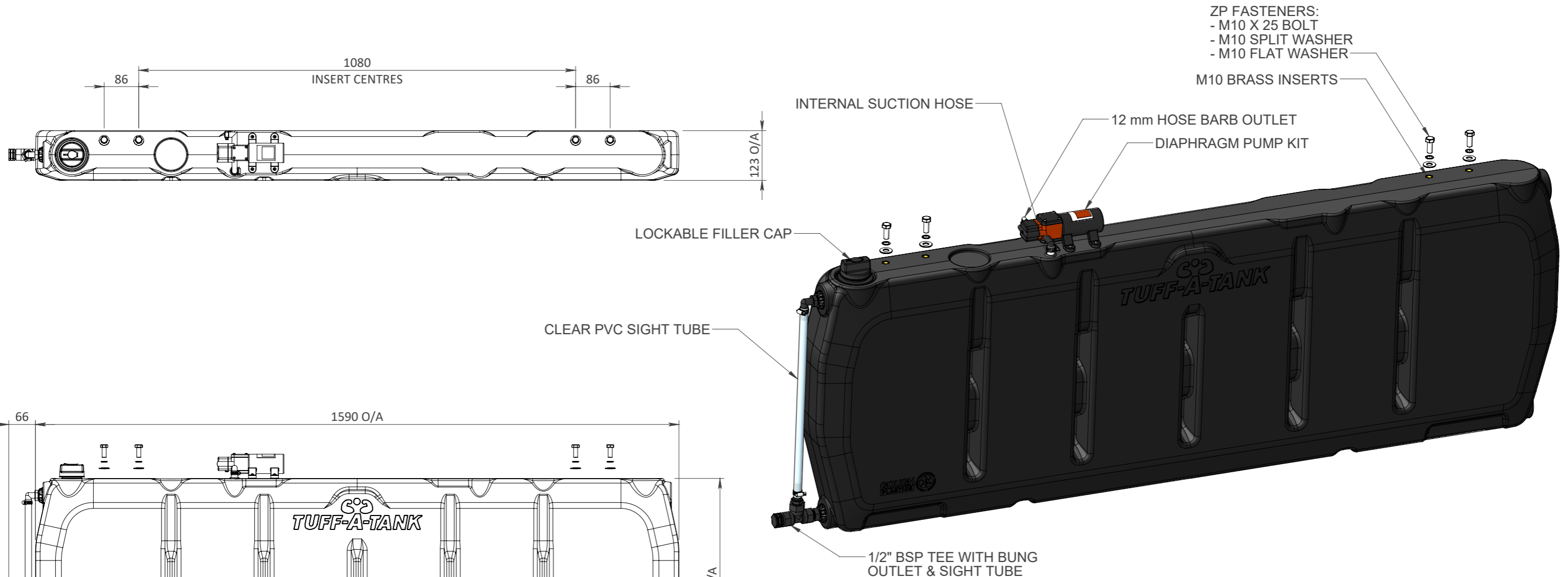

MATERIAL	POTABLE WATER GRADE POLYETHYLENE
WEIGHT	13 KG APPROX DRY
COLOUR	STANDARD BLACK - DARK GREY AVAILABLE
BRACKET KIT AVAILABLE	SOLD SEPARATELY
HOSE KIT AVAILABLE	SOLD SEPARATELY
HIGH PRESSURE LOW FLOW DIAPHRAGM PUMP	12 V - 3.8 LPM - 40 PSI

RINSE TANK PRIOR TO USE

A	23/09/2021	SALES DRAWING	MC	DH	
REV	DATE	REVISION DESCRIPTION	DRAWN	CHKD.	ENG.

**GOUGH
PLASTICS**

A.C.N. 010 028 547
Gough Industries Pty. Ltd.
833 Ingham Road
Bohle, Townsville
P.O. Box 7570, Garbutt BC, Qld. 4814.
Telephone 07 47747606
www.gough.com.au

Dimensions are in millimetres (mm) unless noted.

CLIENT LOGO.

VS - 65 L Canopy Tank Diaphragm WATER Sales

SCALE: NTS A3

GOUGH PLASTICS DRAWING No. **FBOX408.1006.4**

REVISION: **A**

SOLDWORKS: S:\Solidworks\Domestic\Slimlines\Vertical Slimlines\Canopy\VS - 65 L Canopy Tank Assem

PDF FILE PATH: S:\Products\Domestic\Marketing Domestic\VS Tanks